

PM501 LOW COST PANEL MOUNT INTERCOM

The PM501 is a four channel panel mount intercom that was designed to provide both basic intercom capabilities as well as additional features usually found only in more expensive models. The PM501 lends itself well into applications where low cost, ease of use, and high reliability are major considerations.

To provide the pilot and passengers with plenty of audio power, the PM501 provides individual output amplifiers for the pilot, copilot and passengers 1 & 2. This provides enough audio punch to allow communications in very noisy environments. The volume control adjusts the volume for all headsets as well as functions as a Push On/Push Off power switch.

The VOX (Voice Operated Relay) circuit prevents mic audio from getting through the intercom until someone speaks and triggers the VOX open. After a prescribed amount of "delay time", the VOX circuit will close again, allowing the pilot and passengers to take advantage of the noise canceling ability of their headset. The single VOX squelch control adjusts the sensitivity of VOX circuit, allowing optimized trip level adjustment.

The PM501 has an automatic fail-safe interconnect to the aircraft radio. In the event that power is disrupted to the intercom, the pilot's headset will be connected directly to the aircraft radio, providing uninterrupted radio communications.

Provision for an entertainment input is provided allowing the pilot and passengers the option to listen to music during flight. During intercom system activity, the music will automatically mute allowing communications without distraction. Note: The music is not muted during radio reception.

A mode switch allows the selection of two intercom configurations. In the down position, the intercom is in the ALL mode, allowing everyone to hear the aircraft radio, entertainment device and intercom. In the up position, the pilot will be in the ISO or Isolate mode. This mode connects the pilot directly to the aircraft radio for uninterrupted radio communications while the passengers can continue to communicate with each other and listen to music if desired.

Both the pilot and copilot have aircraft radio transmit capabilities. Only the person who presses their PTT will be heard over the radio. If both pilot and copilot press the PTT at the same time, the copilot will override. By turning the intercom off, the pilot will be directly connected to the aircraft radio and will then have aircraft radio priority.

Even though the PM501 is our lowest cost intercom and has the fewest functions available when compared to other PS Engineering intercoms, it has as much quality designed and

manufactured into it as our most expensive intercoms, providing years of trouble free operation.

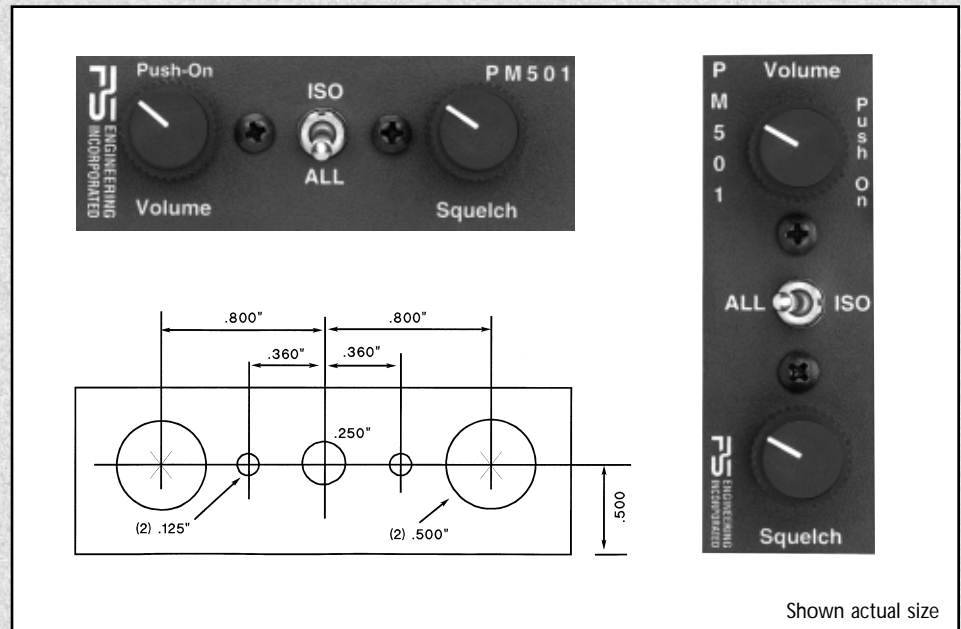

Shown actual size

TECHNICAL SPECIFICATIONS

- Input power:** 12 - 28 Volts DC at < 70mA
- Headphone Impedance:** 150-1000 Ohms Typical
- Audio Distortion:** <10% 75mW into 150 Ohms load
- Total available output power:** 225mW
- Aircraft Radio Impedance:** 1000 Ohms Typical
- 3 dB Mic Frequency Response:** 350 Hz-6000 Hz
- 3 dB Music Frequency Response:** 200 Hz-15 Khz
- Net weight:** 8.5 ounces
- Dimensions:** 0.90" H by 2.60" W by 4.85" D

Optional Configurations: Custom Wire Harness can be made to your specifications. Call for wire harness worksheet.

Warranty

One year hassle-free exchange program, when installed by an authorized PS Engineering dealer. An exchange unit will be shipped by way of Federal Express. After the one year warranty period, a fixed repair fee of \$59.95 will be charged. See Warranty Information in the Installation Manual for more details on our limited warranty.

ORDERING INFORMATION

11800-PM501 Panel Mount
 Four Channel Panel Mount Intercom

11910-Jack Kit

Includes four mic and headphone jacks, insulation washers and music input jack.

PM501 Wiring Diagram

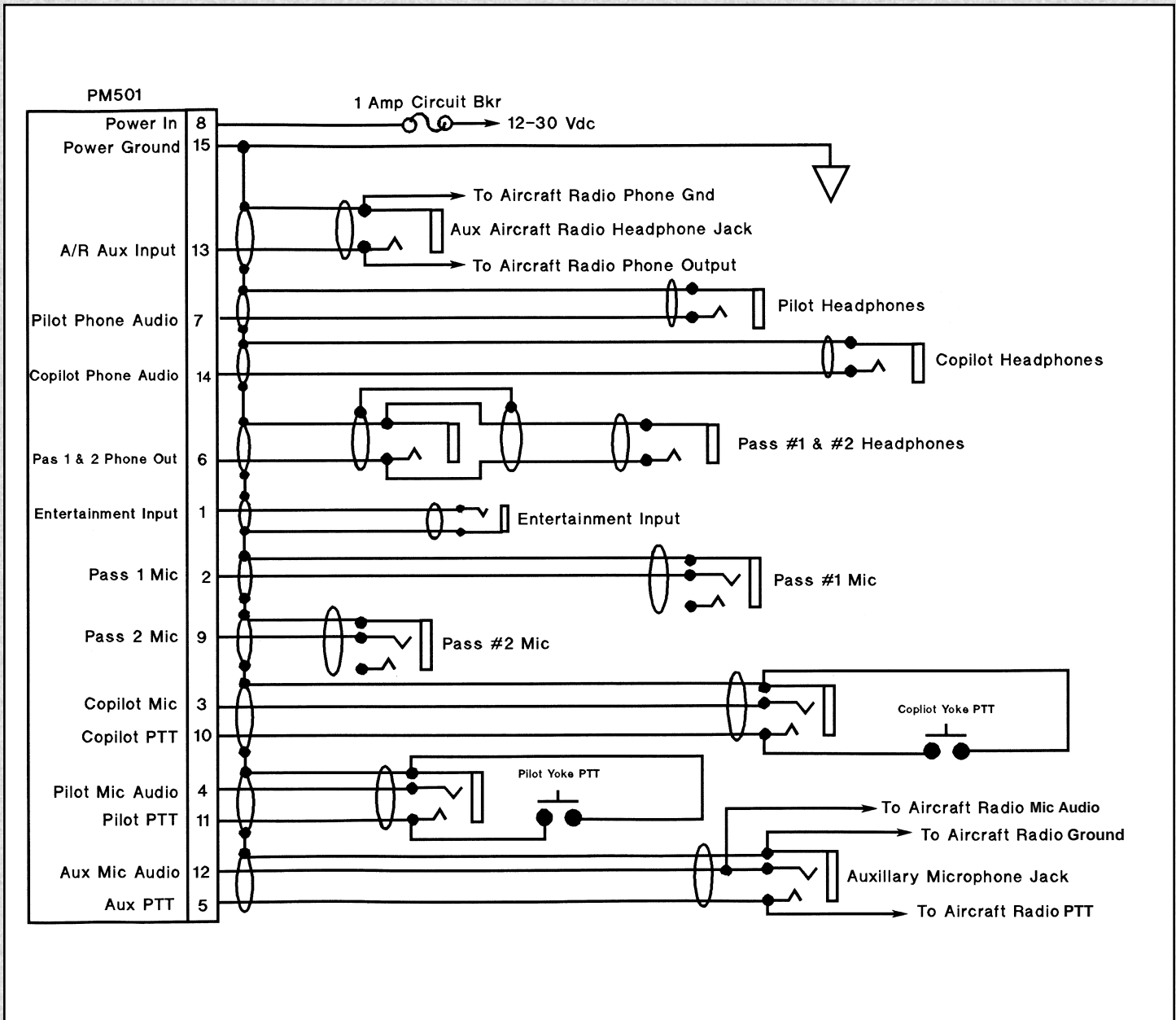

Mode	Pilot Hears	Copilot Hears	Passenger Hears	Comments
Isolate	A/C Radio Sidetone from A/C radio during Xmt.	Copilot Passengers Aux. Input	Passengers Copilot Aux. Input	This mode allows the pilot to communicate with the ground without the copilot or the passengers hearing the conversation. Copilot and passengers can continue to communicate with themselves and hear the Aux Input.
All	Pilot A/C Radio Copilot Passengers Aux Input	Copilot A/C Radio Pilot Passengers Aux Input	Passengers A/C Radio Pilot Copilot Aux Input	This mode allows the pilot and aircraft radio to join the copilot and passenger communications. Music is muted (lowered in level) only during intercom communications. Music and intercom are disabled during radio transmissions.

PS Engineering, Inc. • 9800 Martel Road • Lenoir City, TN 37772

Phone (865) 988-9800 • FAX (865) 988-6619 • Internet www.ps-engineering.com